

TAPROOM DRAFT SYSTEM OPERATIONS & MAINTENANCE



PRESENTED BY NICK KLEIN
NW DRAFT TECHNICIANS

WHO IS NW DRAFT TECHNICIANS

- How we started
- What we specialize in
- How we learned
- How we grew
- What we know now

THE GOALS OF AN ORGANIZED DRAFT SYSTEM

- Profits- Clean and easy to use draft systems lead to higher profits
- Less Liability- An organized draft system is easier to use and manage
- Management- Back ups, pour costs, inventory, gas levels, cleaning schedule
- Change flavors or products you would like to dispense

TYPES OF GAS USED IN DRAFT SYSTEMS

- Co2
- Nitrogen
- Argon
- Blended gas system- A.K.A. Mixed Gas

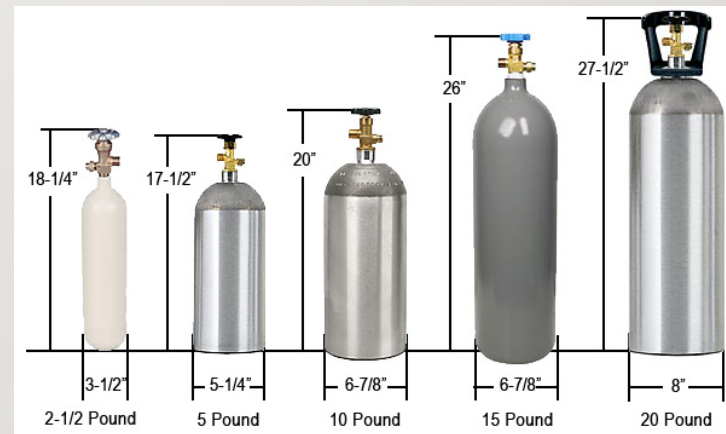

MIXED GAS- A BLEND OF CO2 AND NO2

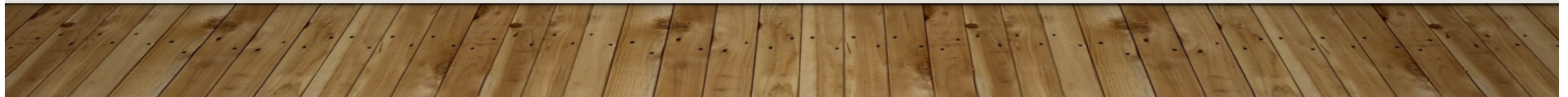
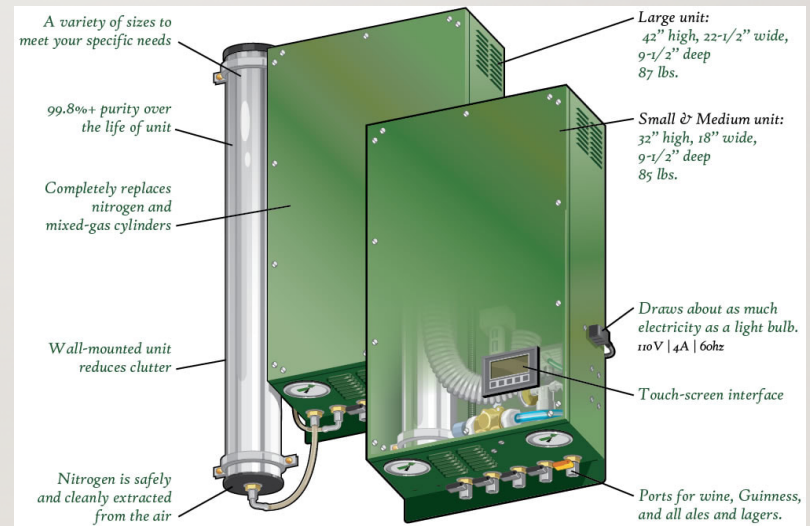

TYPES OF DISPENSE SYSTEM

- Draft Beer System
 - Direct Draw- Most Common
 - Forced Air- For short distances
 - Glycol- Remote Systems

DIRECT DRAW SYSTEM

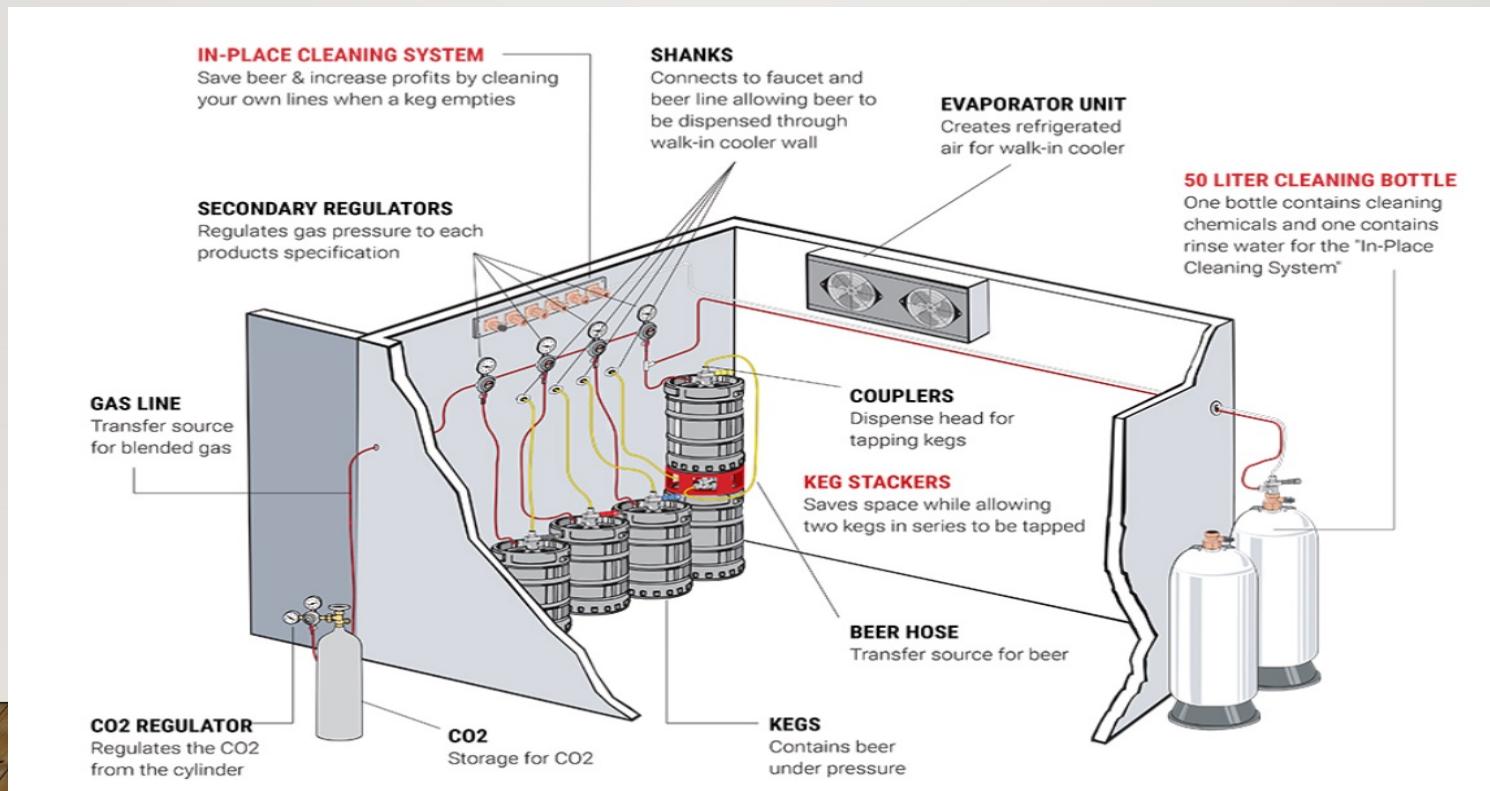

DIRECT DRAW SYSTEM

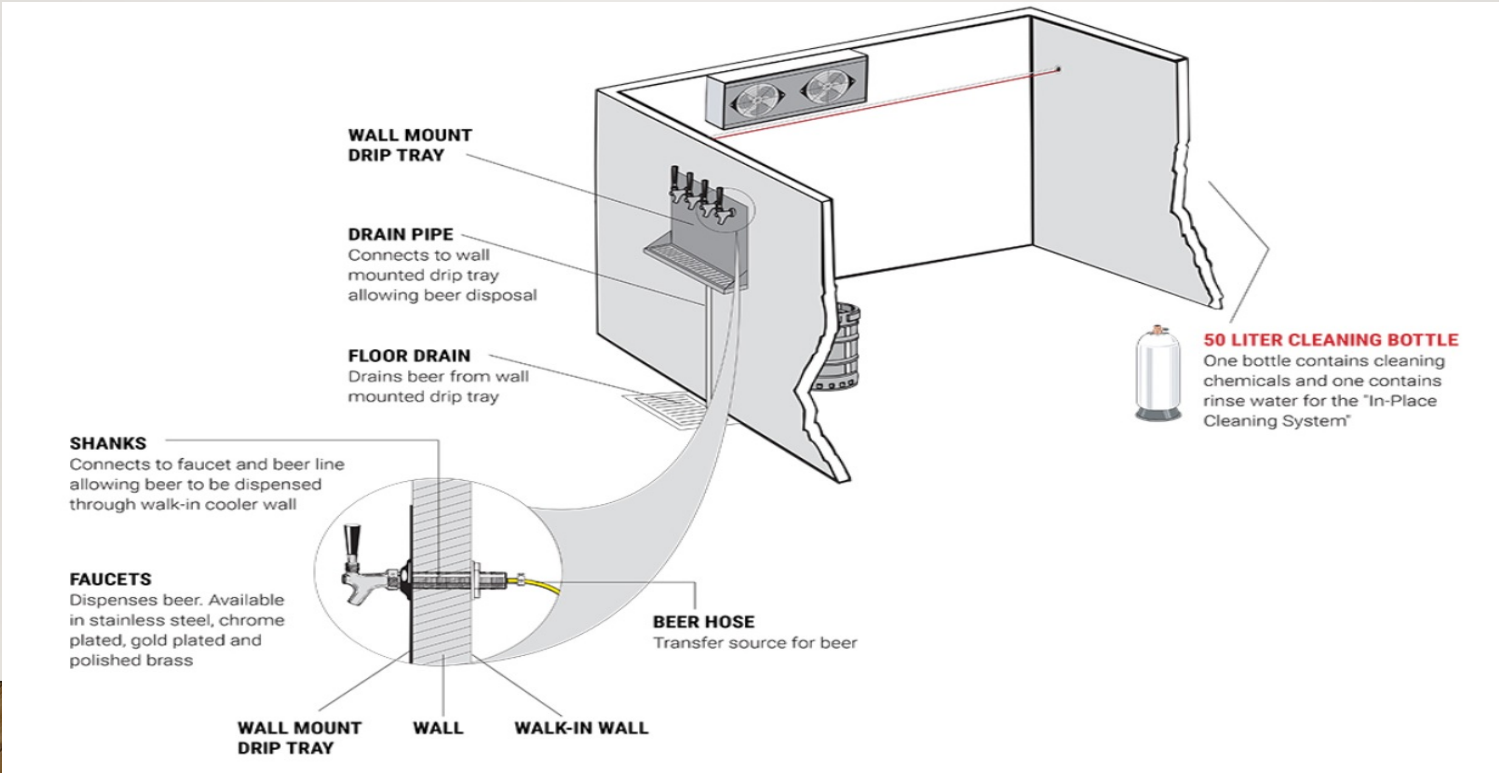

FORCED AIR SYSTEM

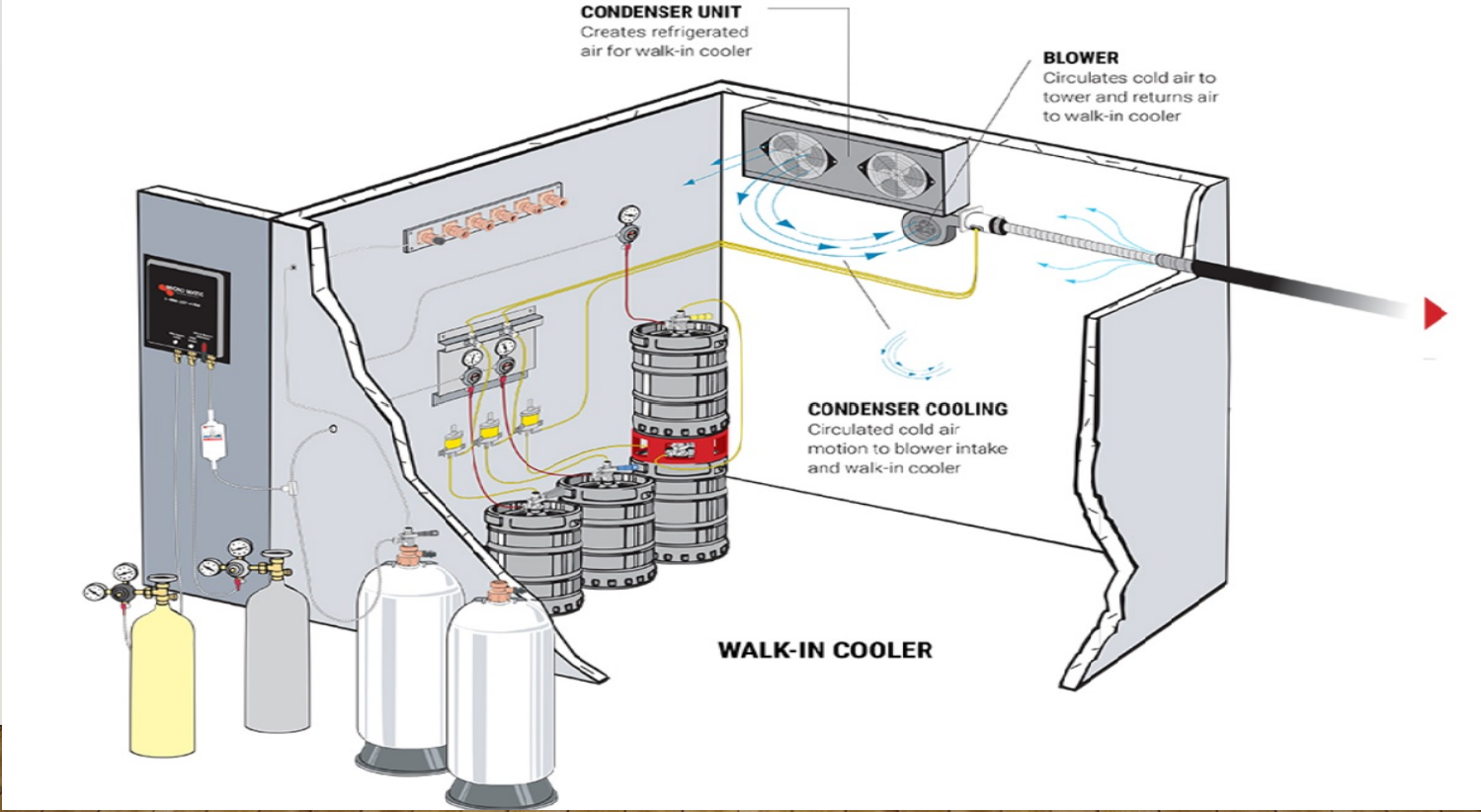

FORCED AIR SYSTEM

CUT AWAY VIEW MUSHROOM TOWER & AIR SEPARATOR KIT AIR CIRCULATION

AIR SUPPLY
Cold air from walk-in cooler is forced up from 2" (or) 3" flexible aluminum tubing then goes through air separator and into tower cooling product lines, shanks and tower cavity.

RETURN AIR
Cool air from tower is forced down through air separator and into 3" (or) 4" I.D. flexible aluminum tubing and forced back to walk-in cooler.

BAFFLE PLATE
Connects together on top of air separator. Maintains proper flow of supply air and return air in tower.

MOUNTING FLANGE
Mounts under bar. Flexible aluminum tubing inserts into mounting flange and is secured with screws or tape.

2" (OR) 3" I.D. FLEXIBLE ALUMINUM TUBING
Connects to air separator, forcing cold supply air to tower.

1/2" THICK FOAM INSULATION
connects flush with bottom of mounting flange creating an air tight seal

INSULATION
Installed into cavity of tower helps to keep tower from sweating and maintains temperature

AIR SEPARATOR
Connects together with the mounting flange. Allows supply air and return air to direct flow properly.

4" I.D. FLEXIBLE ALUMINUM TUBING
Inserts and extends up into top of mounting flange forcing cool return air to walk-in.

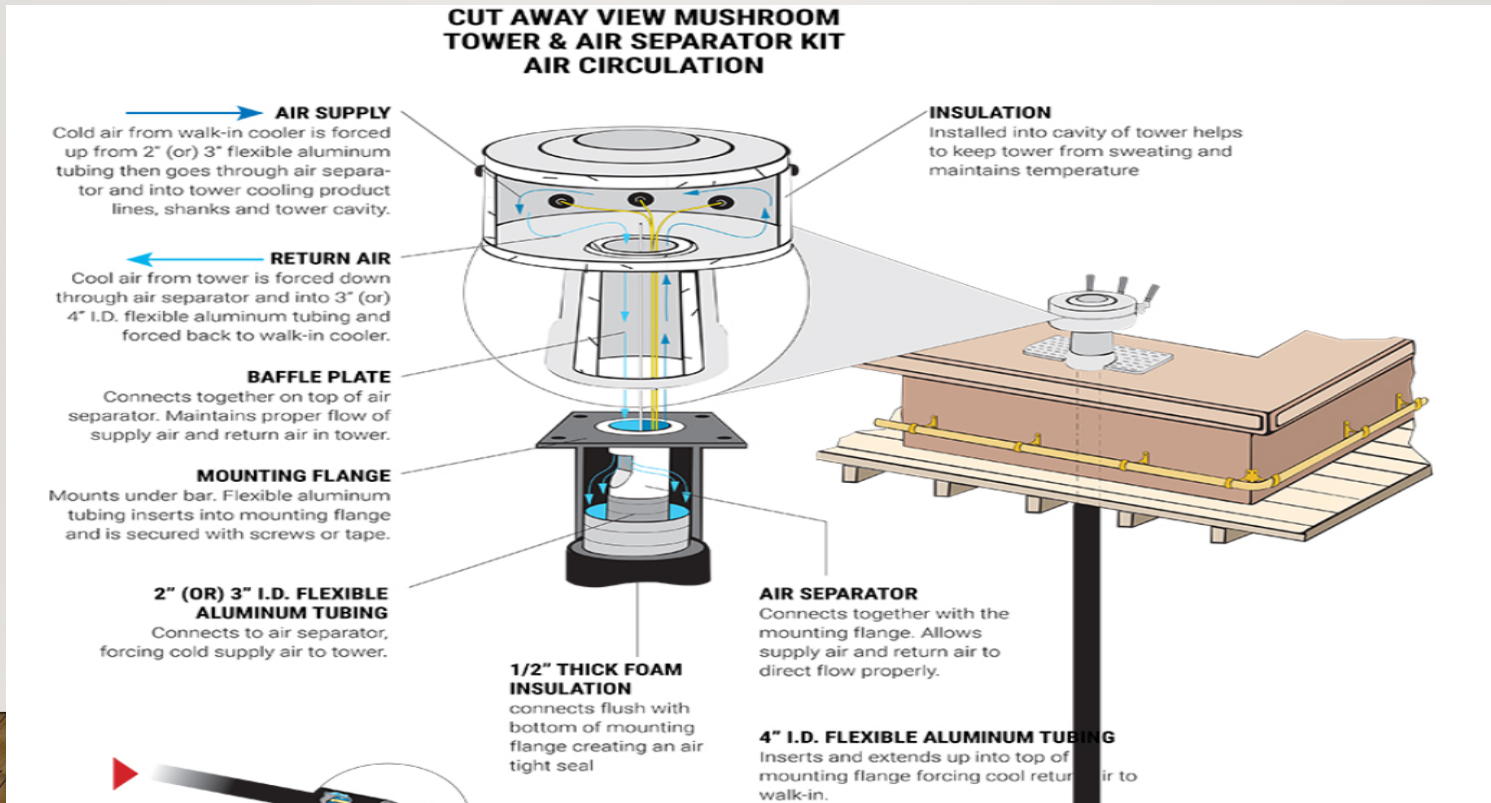

FORCED AIR SYSTEM

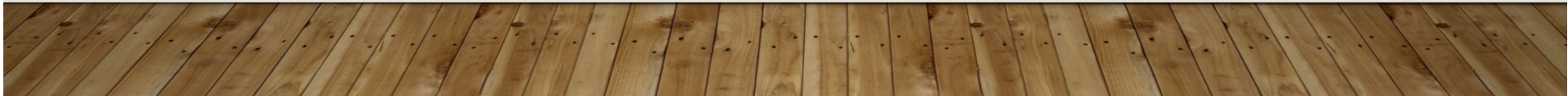
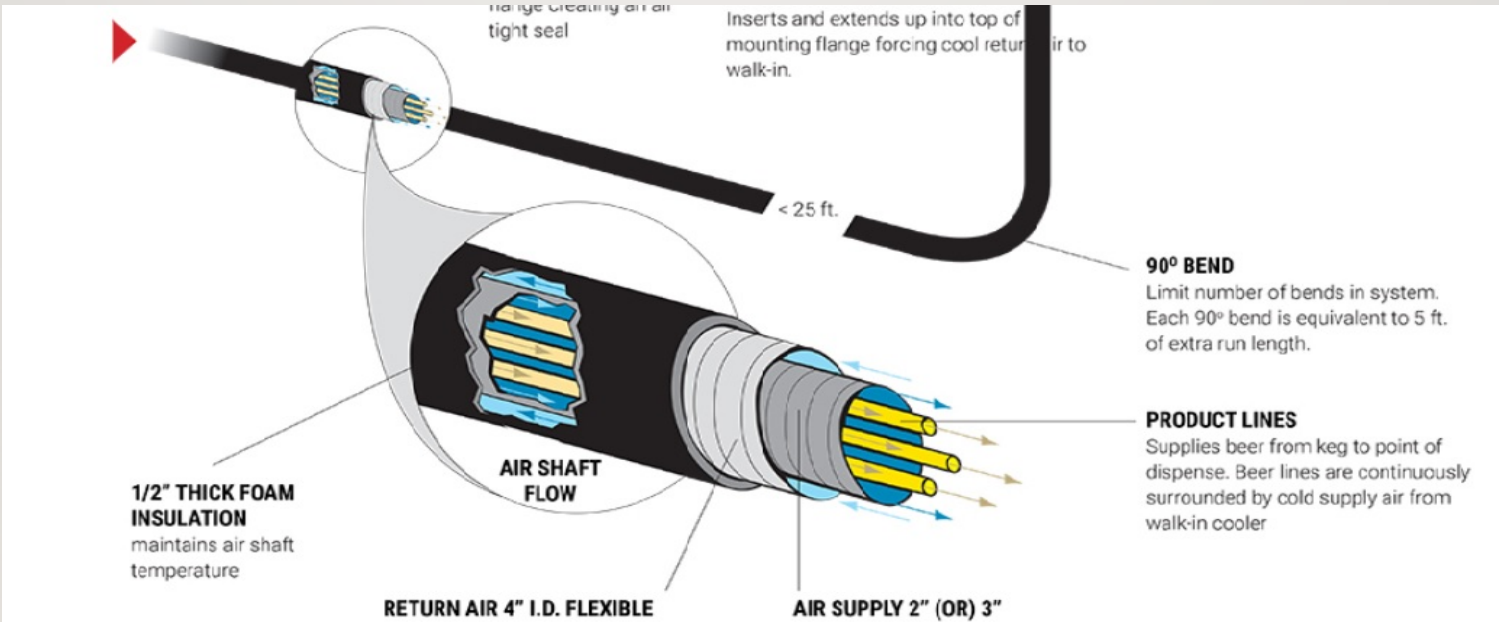

GLYCOL SYSTEM

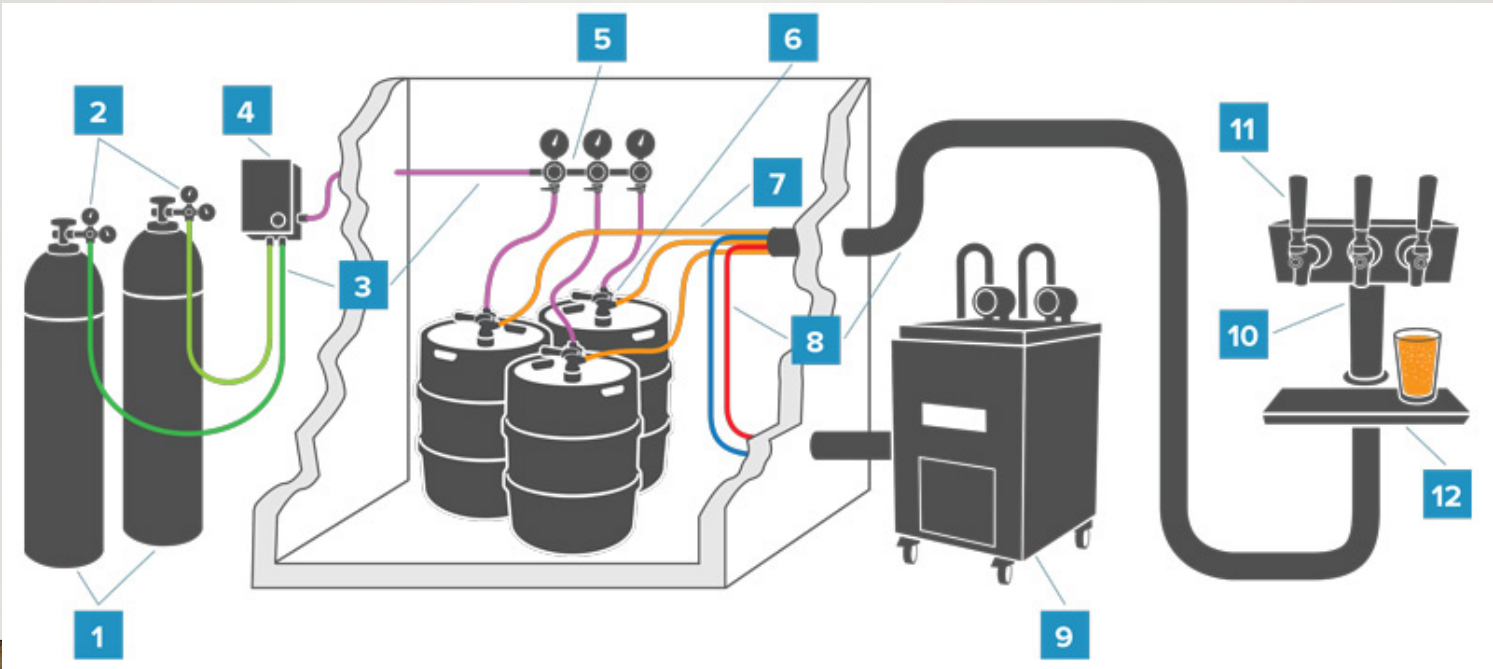

IMPORTANCE OF A PROPERLY BALANCED BEER SYSTEM

- Equal pressure going in to the keg as coming out.
- High Yield
- Low waste
- Proper carbonation means having a 1/2 inch head, not only does that produce the best looking product, but also the best tasting. The head releases the aroma of the beer. Half of taste is smell.

COOLER LAYOUT

- Kegs should be in the same left to right organization as the tower layout
- Organize gas sources with colored gas lines
 - Red for Co₂
 - Blue for No₂
- Keep flavors together

EXAMPLES

ANGELS SHARE BARREL HOUSE



IMPERIAL BOTTLE SHOP- ALBERTA



CLEANING AND MAINTENANCE

- Every 2 Weeks
- Brewers Association of America
- What to look for while cleaning
 - General Cleanliness
 - Washer Condition
 - Sanki Cleanliness
 - Gas Levels
 - Glycol Levels

LACK OF CLEANING

BEER STONES



DIRTY SANKI



LACK OF CLEANING

DIRTY SLIDES

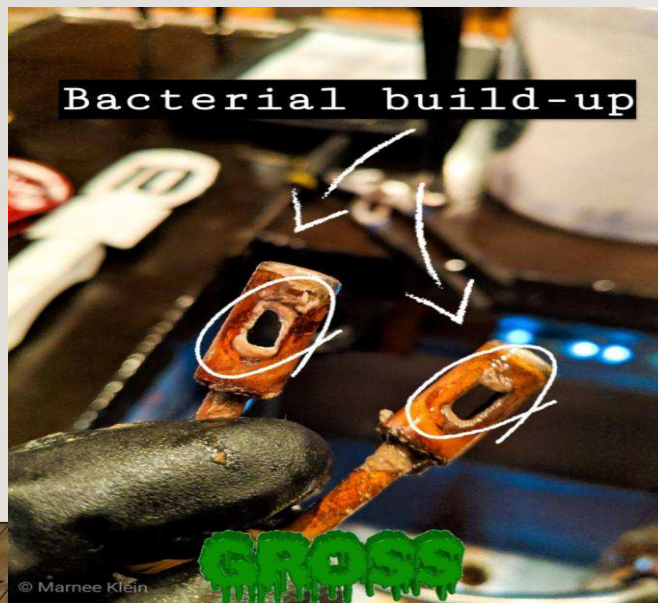

DIRTY FAUCETS



THANK YOU!

Nick Klein

NW Draft Technicians

503-730-2989

Nick@nwdrafttechnicians.com

WWW.NWDRAFTTECH.COM

@northwestdrafttech